

t2100 SERIES

ARC SPRING COUPLING



DESCRIPTION

The t2100 is an arc spring coupling especially designed for deployment in test beds. It works like a dual mass flywheel. Because of its modular spring design, it is possible to tailor its stiffness behavior to the unit under test.

NAMING

The product is named according to the following convention:

t2100-ttt-cccc-CVxx

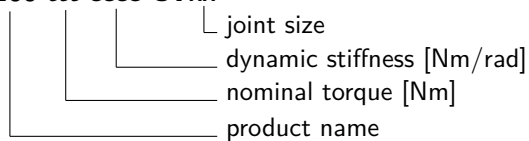

Example: *t2100-260-315-CV15*

OPERATING RANGE

Torque: up to 400 Nm
Speed: up to 10000 rpm

BENEFITS

- suitable for high dynamic loads
- high damping and long lifetime
- stiffness adjusted by spring placement
- wide stiffness range

FUNCTION

As for a vehicle dual mass flywheel, the test bed dual mass flywheel boasts exceptional damping behavior.

Stiffness adjustment is achieved by using different spring configurations in the arc spring coupling. The standard t2100 specifications cover a nominal torque range of 160 - 400 Nm for a torsional stiffness of 200 - 500 Nm/rad.



t2100 SERIES

ARC SPRING COUPLING

Coupling	Joint	T_{KN} [Nm]	C_{Tdyn} [Nm/rad]	T_{Kmax} [Nm]	n_{max} [rpm]	m [kg]	x_s [mm]	J_1 [kgm ²]	J_2 [kgm ²]	Ψ [-]	d [Nms/rad]	φ_{max} [°]
t2100-160-200	CV05	160	200	200	10000	7.05	21.7	3.72E-02	6.55E-03	0.8	2.0	57
	CV15	160	200	200		6.96	18.7	3.72E-02	6.48E-03			
t2100-260-315	CV05	260	315	315		7.37	21.5	3.85E-02	7.80E-03			
	CV10	260	315	315		7.05	20.9	4.14E-02	3.14E-03			
	CV15	260	315	315		7.28	18.7	3.85E-02	7.73E-03			
t2100-400-500	CV05	400	500	500		7.30	21.6	3.77E-02	7.70E-03			
	CV10	400	500	500	7.14	20.9	3.76E-02	7.39E-03				
	CV15	400	500	500	7.17	21.1	3.77E-02	7.70E-03				

T_{KN} - Nominal torque¹
 C_{Tdyn} - Torsional stiffness
 T_{Kmax} - Maximum torque
 n_{max} - Maximum speed

m - Mass
 x_s - Center of gravity flange-side
 J_1 - Inertia flange-side
 J_2 - Inertia shaft-side

Ψ - Relative damping
 d - Damping
 φ_{max} - Maximum torsional angle

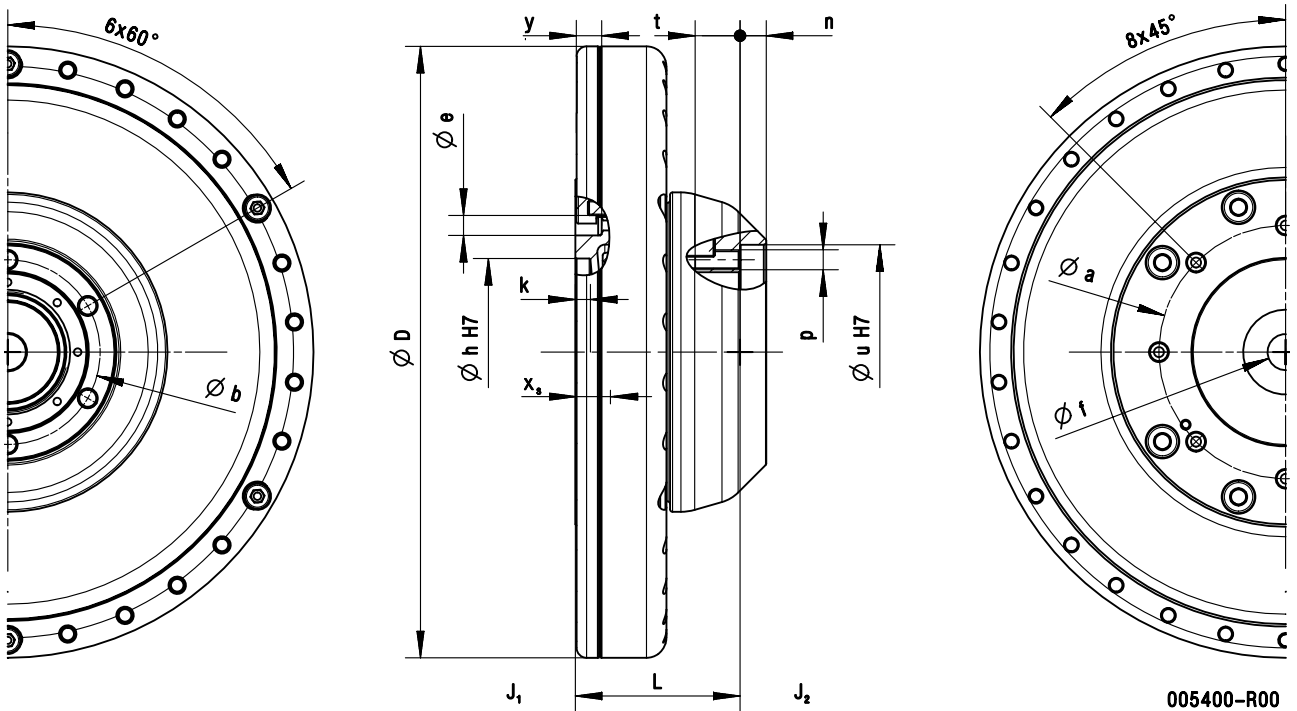

Coupling	Joint	D	L	a	b	e (D7)	f	h (H7)	k	n	p	t	u (H7)	y
		[mm]	[mm]	[mm]	[mm]	[mm]	[mm]	[mm]	[mm]	[mm]	[-]	[mm]	[mm]	[mm]
t2100	CV05	245	66	101.5	74	8	14.5	75	6	10.5	M8	18	86	10
	CV10	245	66	101.5	80	8	14.5	75	6	4.5	M8	18	94	10
	CV15	245	66	101.5	94	8	14.5	75	6	4.5	M10	22	108	10

Other dimensions available on request

¹The nominal torque must be equal to or greater than the maximum combustion engine torque