

tDock1000

AUTOMATIC DOCKING SYSTEM



DESCRIPTION

The tDock1000 docking system has been designed for fast automatic docking of engines for quality control and production testing. This docking system combines the high alignment capability of CV joints with the reliable functionality provided by a splined docking mechanism. This unique docking system enables efficient docking and guarantees extremely smooth running of the test bed.

OPERATING RANGE

Torque: up to 1500 Nm
Speed: up to 10000 rpm

BENEFITS

- direct mounting on engine flange allows easy attachment to the engine
- engine adapter can be individually customized and is easy to change
- inertia value similar to the original engine flywheel
- play-free, self-centering
- low-noise, low-vibration and low-maintenance
- secure and easy docking
- compact and modular design
- long life
- reduced docking time



tDock1000

AUTOMATIC DOCKING SYSTEM

tDock1000-CV10		
Maximum torque T_{max}	[Nm]	1500
Maximum speed n_{max}	[rpm]	10000
Mass (without customer-specific adapter)	[kg]	7.01
Inertia (without customer-specific adapter)	[kgm ²]	2.02E-02

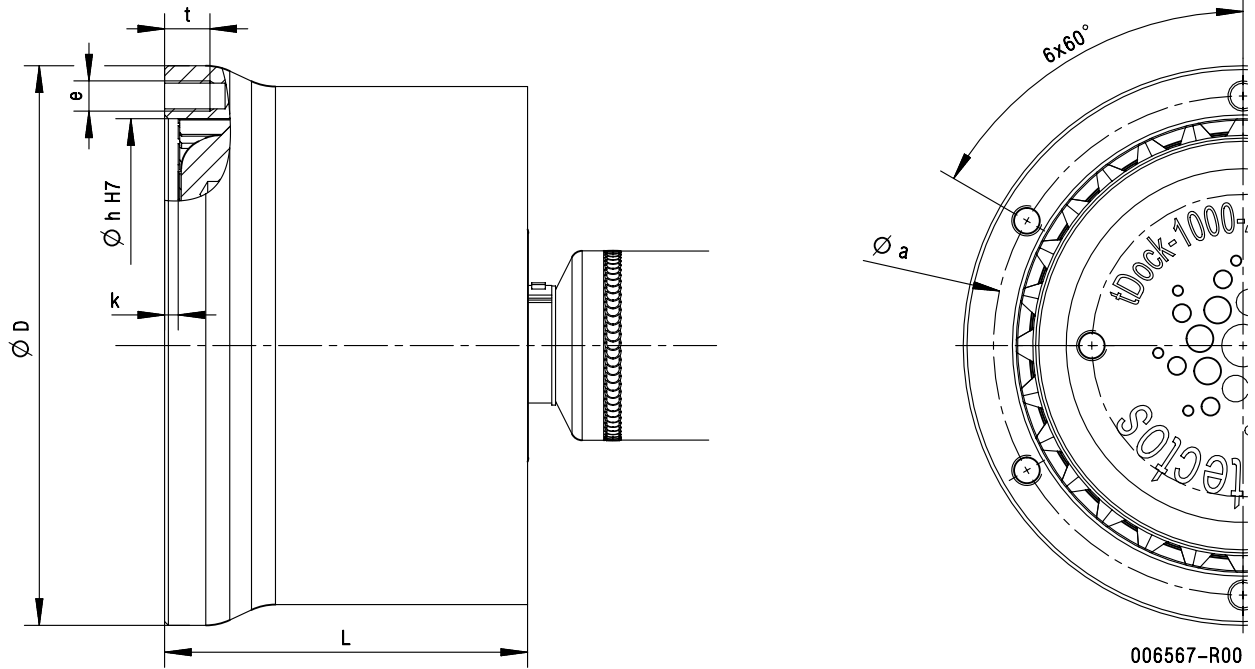

Docking system	Joint	L	D	a	e	h (H7)	k	t
		[mm]	[mm]	[mm]	[-]	[mm]	[mm]	[mm]
tDock1000	CV10	96	148	132	M8	120	3.6	12

Other dimensions available on request