



### DESCRIPTION

The modular tLEA, gearbox dummy is the answer to increased complexity of the interaction between internal combustion engine and gearbox. You can use the tLEA to measure the engine in the test bed without the gearbox influencing the results. The connection is made using the original gearbox interfaces.

The tLEA gearbox dummy can be supplemented by the optional operating unit (see tPIA separator coupling).

### OPERATING RANGE

Torque: up to 1100 Nm  
Speed: up to 10000 rpm

Higher torques and speeds are available on request.

### BENEFITS

- modular design
- direct interface to the coupling
- adaptable use of coupling
- integrated temperature monitoring
- mechanical separation of the drive train during operation is possible



# tLEA

## GEARBOX DUMMY

tLEA		
Installed length	[mm]	728.8
Height	[mm]	407
Width	[mm]	452
Weight m	[kg]	45
Maximum torque $T_{max}$	[Nm]	1100
Maximum speed $n_{max}$	[rpm]	10000
Inertia J	[kgm <sup>2</sup> ]	1.69E-01
Minimum operating temperature $\vartheta_{min}$	[°C]	-20
Maximum operating temperature $\vartheta_{max}$	[°C]	+80

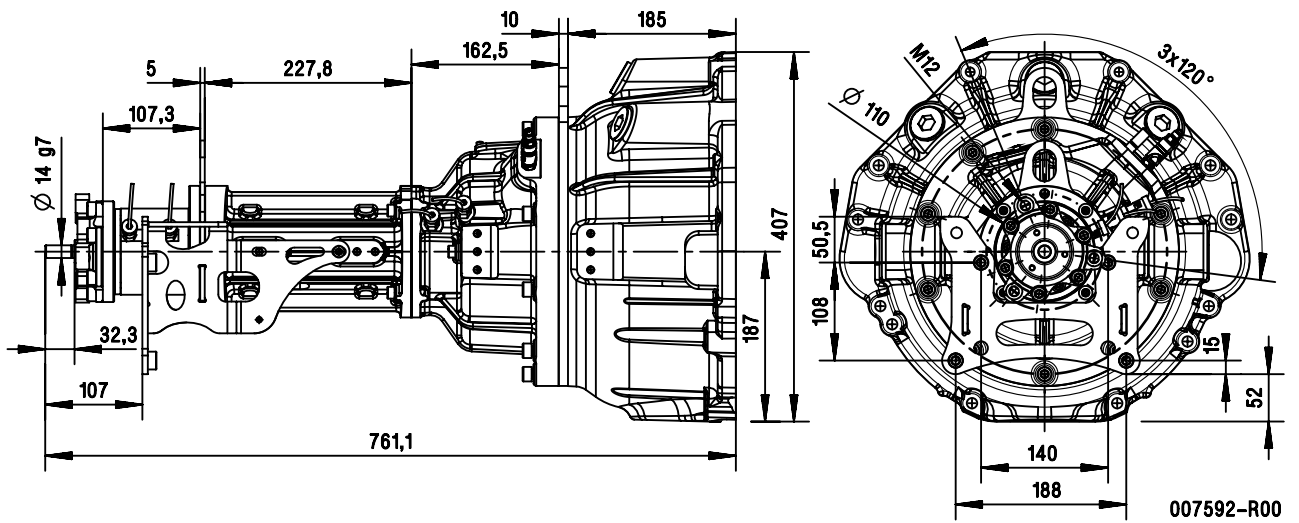

The technical data and the measurements drawing provided serve as an illustrative example.

Each tLEA separator coupling is adapted to customer-specific needs.